



Positioning systems made to measure.

OEM Machines

Positioning Systems

Modules

Components

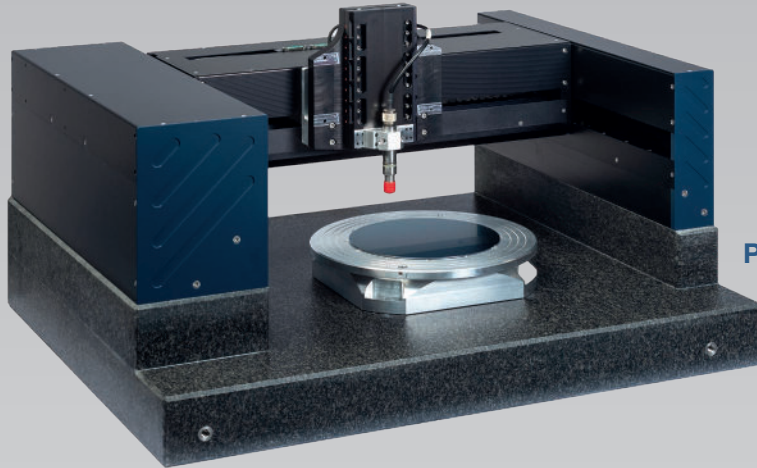

PT15 positioning unit in gantry design



PT15 Positioning Unit in Gantry Design

The products of the PT15 series, available in various basic versions, form the basis for positioning with systems from ITK. Optimising each system flexibly and according to customer requirements is our speciality. Thanks to the modular design and the use of our own components, we can offer you a customised solution

Key Features.

- Very compact and accurate structure in gantry design
- $< \pm 3 \mu\text{m}$ absolute accuracy in both directions
- $< \pm 0,5 \mu\text{m}$ repeatability
- Position resolution 50 nm
- Travel speed: 1 $\mu\text{m/s}$ to 2.5 m/s
- $> 30 \text{ m/s}^2$ or 3 g maximum velocity
- High absolute accuracy due to ground hard stone structure
- Sensors or similar elements can be moved from above onto the object to be examined
- Internal cable drag chain including free cable for the application
- Different Z-axes can be mounted, including double or quadruple Z adjustment

based on your specifications. All the systems used have one thing in common: they are 100 per cent cleanroom compatible and absolutely reliable - even in continuous 24/7 operation. Scanner areas of up to 4 m² are available as standard, larger areas are possible on request.

Your Advantages.

- Very stable construction based on hard stone - for highest positioning accuracy
- Travel range up to 1.7 m²
- Variable passage heights for the products to be analysed
- Dynamic direct drive by linear motors in X, Y, Z direction
- Very wide speed range
- Number of Z axes: Various options on request
- Clean room compatible according to ISO14644-1 class 5
- Designed for continuous use
- Reduction of heat generation by using ITK's own linear motors
- Customised designs possible



Highlights.

Your partner for complete systems for High precision positioning tasks.

On the way to ever more accurate and flexible systems, we have continuously expanded and optimised our product portfolio. The result is impressive. But it can also be measured: we can display a position resolution of up to 5 nanometres at system level.

Our gantry tables are mostly of classic gantry design and are used wherever relatively light workpieces and specimens have to be positioned with high precision and dynamically.

With ITK, you always get a complete solution and only one contact person who advises you on all technical details and takes care of the entire process - from the enquiry to commissioning and training. Thanks to the modular structure and the use of our own components, we can offer you a customised solution based on your specifications. We can realise your project many times faster and more efficiently than you might expect - we will be happy to make you an offer.

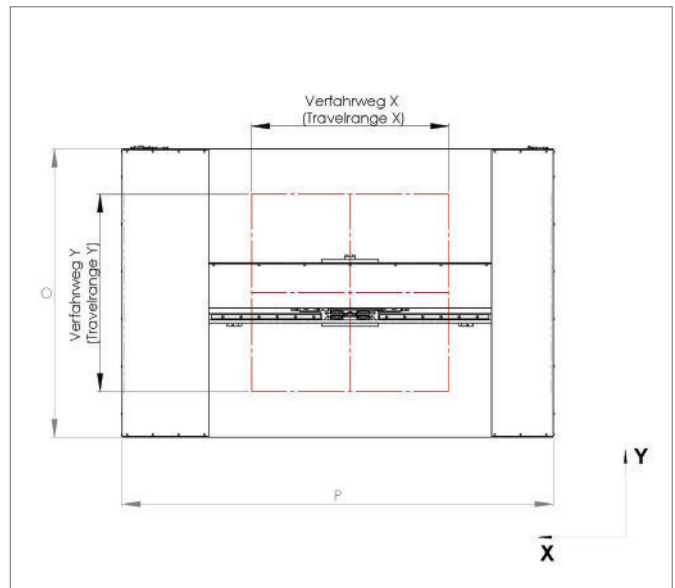
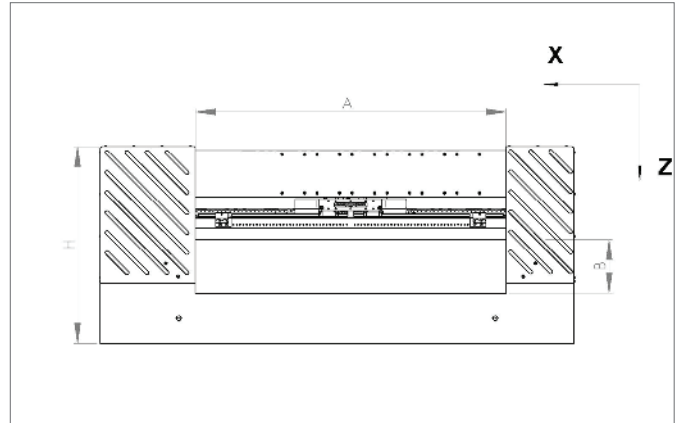

Technical Data.

Dimension	Unit	PT15A	PT15B	PT15G
A	[mm]	687	770	1588
B	[mm]	200	150	260
H	[mm]	385	480	738
O	[mm]	800	855	1600
P	[mm]	920	1190	2072
Travel range X	[mm]	320 ... 400	300 ... 500	650 ... 1300
Travel range Y	[mm]	320 ... 400	300 ... 500	650 ... 1300
Total weight	kg	200 ... 300	320 ... 500	800 ... 2450

Comparison of positioning system series with granite base plate

PT15 Variant	High repeatability	High positioning accuracy	High resolution	High travel speed	High acceleration	Max. Traglast [kg]															
						0	2	4	6	8	10	12	14	16	18	20					
-A	■ ■	■ ■ ■	■ ■ ■	■ ■	■ ■																
-B	■ ■	■ ■ ■	■ ■ ■	■ ■	■ ■																
-C*	■ ■ ■	■ ■ ■	■ ■ ■	■ ■ ■	■ ■ ■																
-G	■	■	■ ■ ■	■ ■	■																

Note: the more ■ the better.

*Look forward to our **new PT15C variant** with novel design and use of lightweight materials for maximum dynamics while maintaining high precision.

Accessories.

Our PT15 positioning systems can be optionally expanded with various Z-axis modules. The axis modules are driven by means of a linear motor or spindle. In addition, we offer corresponding measuring systems. The assembly of the required Z-axes can be done by the customer.

ITK provides you with a complete solution: from consulting to commissioning, you receive every-thing from a single source and inhouse made in Germany. We will be happy to advise you.

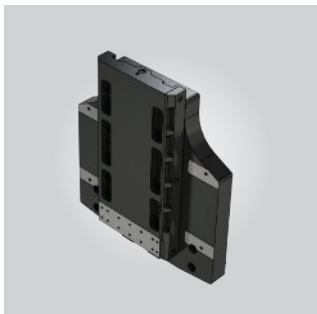

Single-axis Z-module (01011003001)

- 100 mm travel range
- Closed-loop
- High-speed version optional



Double-axis Z-module (01011003003)

- 70 mm travel range
- Closed-loop
- High-speed version optional
- Optimised for 8" and 10" wafers

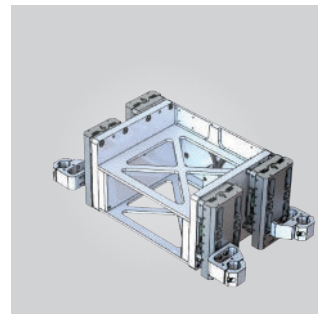

Four-axis jib (01011004003)

- 50 mm travel range
- Closed-loop

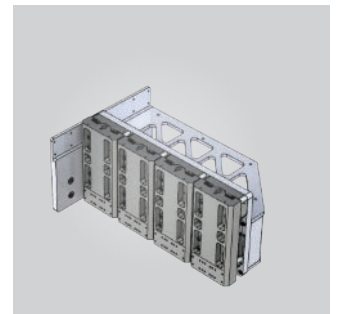

Four-axis extension arm (01011004010)

- 50 mm travel range
- Closed-loop

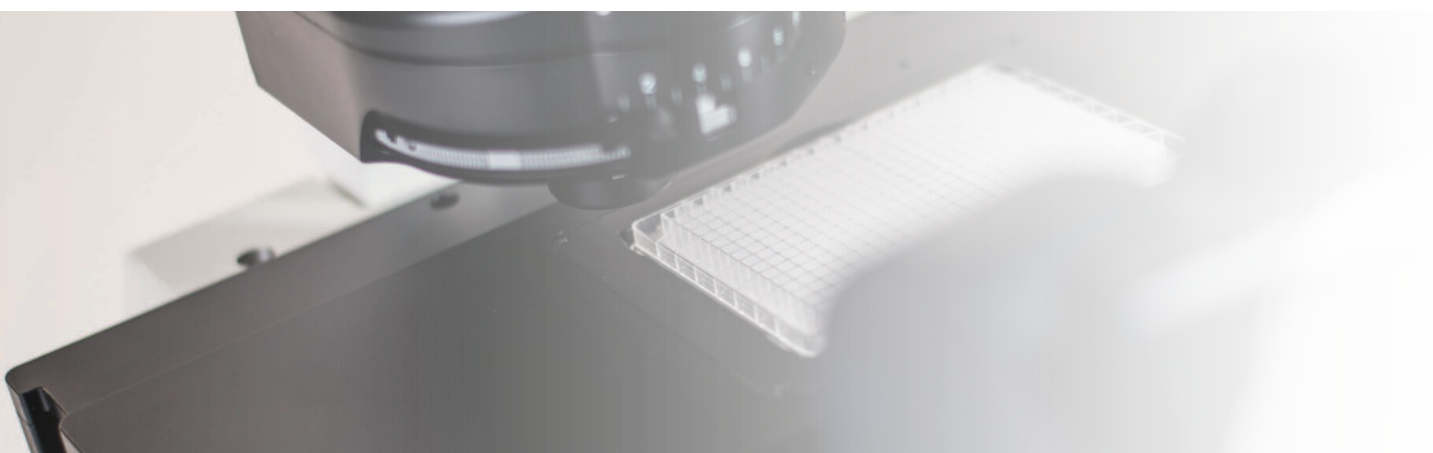

Typical Applications.

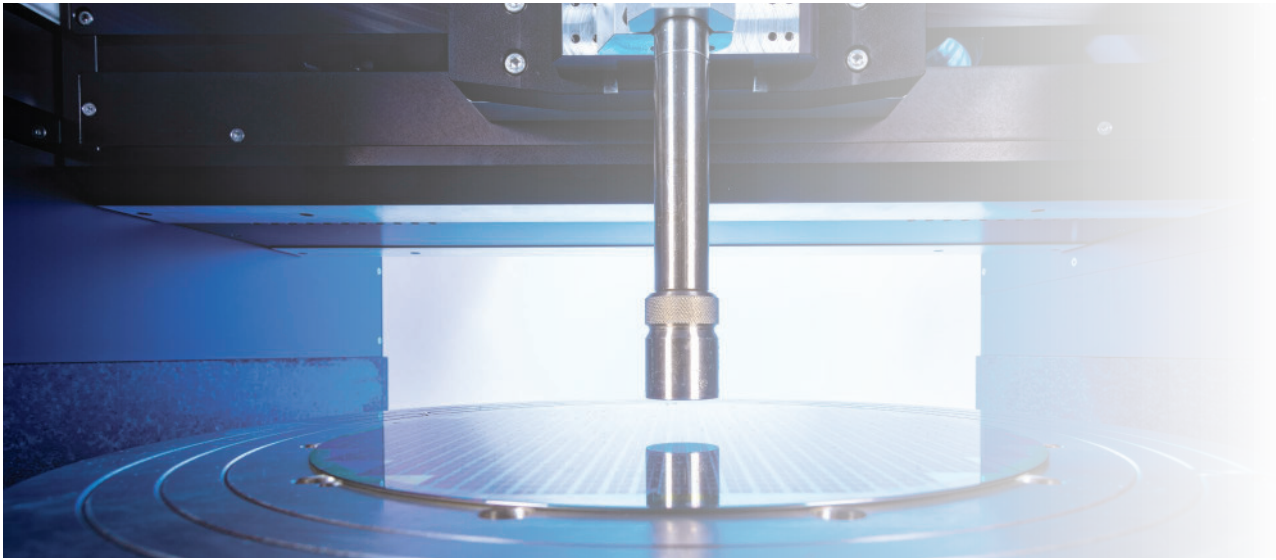

The areas of application for our PT15 positioning systems are diverse: whether for wafer inspection, for material examination or in classical metrology - our systems offer the required high dynamics and positioning accuracy everywhere.

Even when used under difficult conditions, for example in the water bath of ultrasonic testing, our systems function in 24/7 operation. They owe this in particular to the MR-based sensors used.

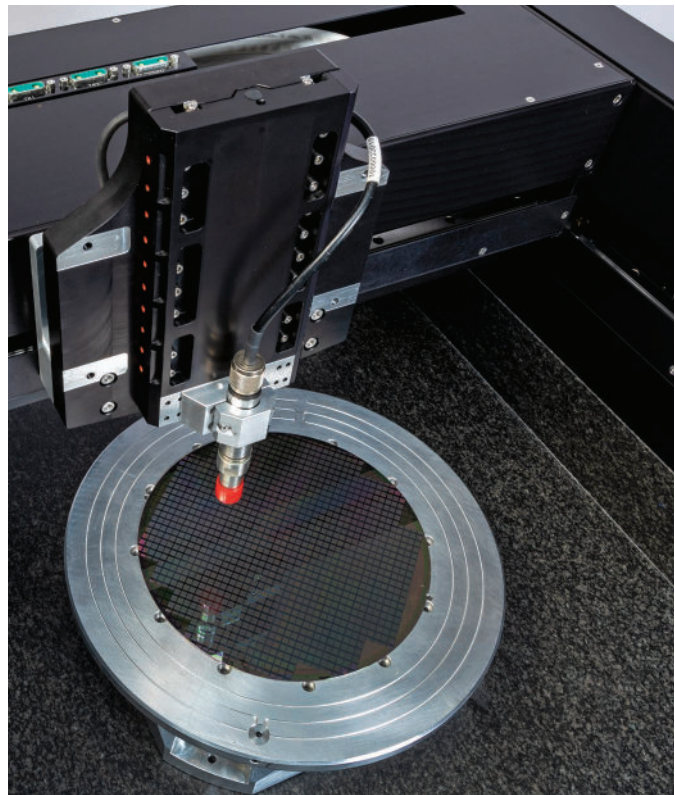

October 2024
Subject to technical changes.